



65046

©2023 Bestway Inflatables & Material Corp.

All rights reserved/Tous droits réservés/Todos los derechos reservados/Alle Rechte vorbehalten/Tutti i diritti riservati

Trademarks used in some countries under license from/

Marques utilisées dans certains pays sous la licence de/

Marcas comerciales utilizadas en algunos países bajo la licencia de/

Die Warenzeichen werden in einigen Ländern verwendet unter Lizenz der/

Marchi utilizzati in alcuni paesi concessi in licenza a

Bestway Inflatables & Material Corp., Shanghai, China

Manufactured, distributed and represented in the European Union by/

Fabriqué, distribués et représentés dans l'Union Européenne par/Fabricado, distribuido y representado en la Unión Europea por/

Hergestellt, vertrieben und in der Europäischen Union vertreten von/Prodotto, distribuito e rappresentato nell'Unione Europea da

Bestway Europe S.p.a., Via Resistenza, 5, 20098 San Giuliano Milanese (Milano), Italy

Distributed in Latin America by/Distribué en Amérique latine par/Distribuido en Latinoamérica por/Distribuído na América Latina por

Bestway Central & South America Ltda, Salar Ascotan 1282, Parque Enea, Pudahuel, Santiago, Chile

Distributed in Australia & New Zealand by **Bestway Australia Pty Ltd, Unit 2/98-104 Carnarvon St Silverwater, NSW 2128, Australia**

Tel: Australia: +61 2 9037 1388; New Zealand: 0800 142 101

Distributed in United Kingdom by **Bestway Corp UK Ltd, 8 Wentworth Road, Heathfield Industrial Estate, Newton Abbot, Devon, TQ12 6TL**

Exported by/Exporté par/Exportado por/Exportiert von/Esportato da

Bestway (Hong Kong) International Ltd./Bestway Enterprise Company Limited

Suite 713, 7/Floor, East Wing, Tsim Sha Tsui Centre, 66 Mody Road, Kowloon, Hong Kong

www.bestwaycorp.com

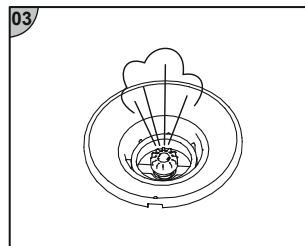
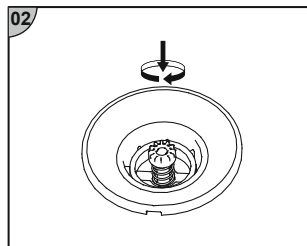
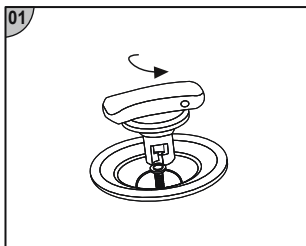
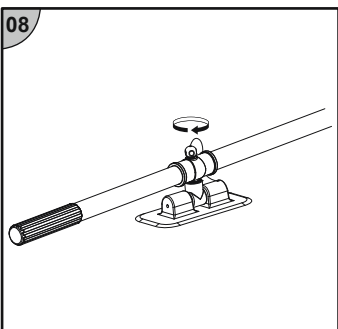
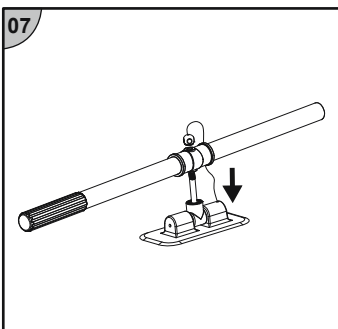
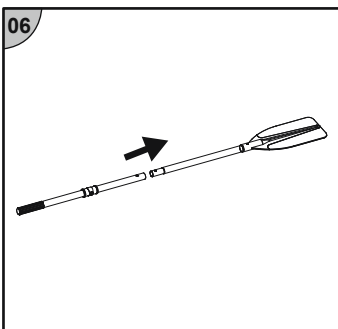
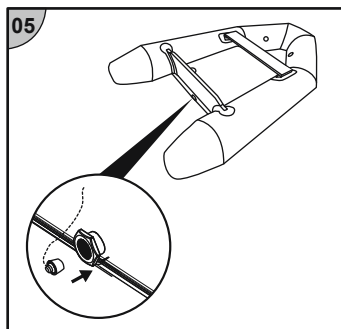
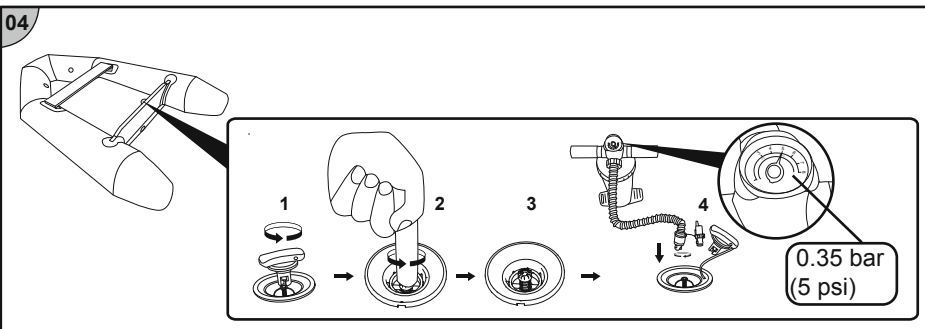
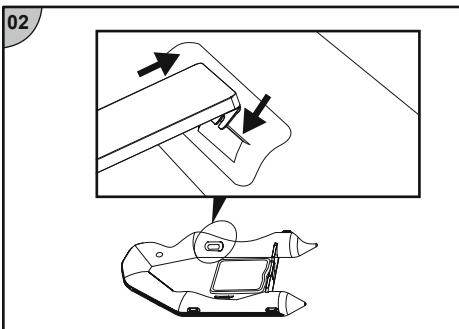
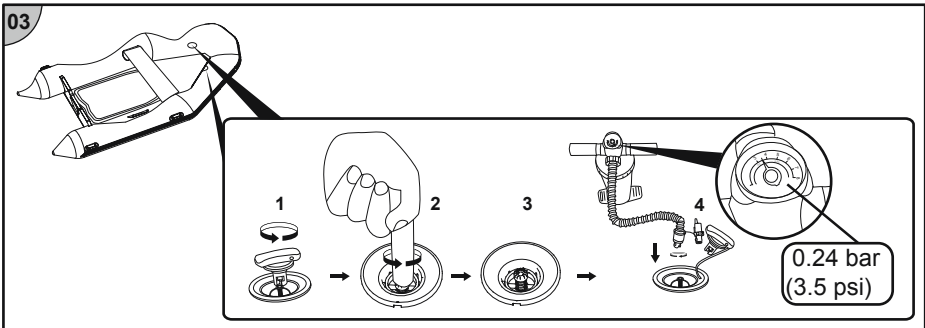
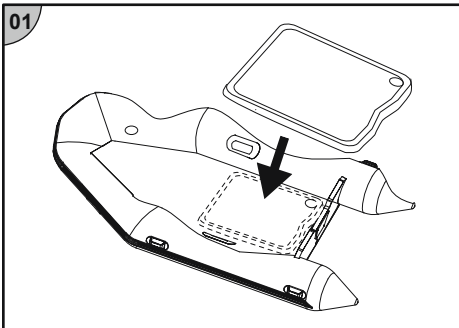
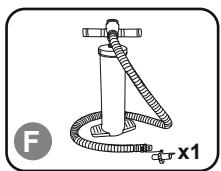
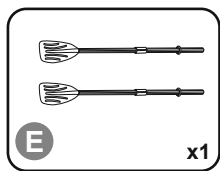
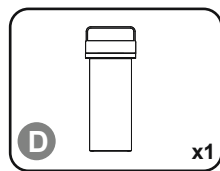
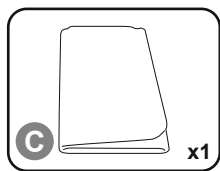
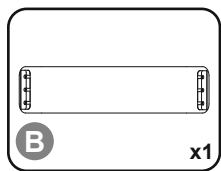
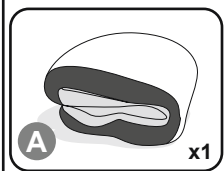

OWNER'S MANUAL

IMPORTANT SAFETY INSTRUCTIONS

WARNING

Follow all the Safety and Operating Instructions. If you don't follow these instructions, it may cause overturn, explode the boat and causes to drowning.

- Before every use, carefully inspect all boat components including air-chambers, grab ropes, oars, and air valves, to ensure everything is in good condition and tightly secured. Please stop to repair if you find any damage.
- Passenger numbers and load weights shall by no means exceed specified capacities. Refer to the Technical Specifications section of this manual to determine passenger numbers and load weights for your boat. Overweight will cause overturn and drowning.
- Inflate according the numbered air chamber and rated pressure on the boat, or it will cause overinflation and boat explosion. Exceeding the data given on the capacity plate may cause the craft to damage, overturn and lead to drowning.
- Keep the boat balanced. Uneven distribution of persons or load in the boat may cause overturn the boat and drowning.
- **BE AWARE OF OFFSHORE WINDS AND CURRENTS.**
- Don't leave the boat exposed to sun for long periods of time, as high temperatures can increase air expansion, which can cause irreparable damage.
- Never transport the boat in inflated condition on the car. Be aware of the potential harmful effects of liquids such as battery acid, oil, petrol. The liquids may damage your boat.

TECHNICAL SAFETY INSTRUCTIONS

- Follow these instructions to avoid drowning, paralysis or other serious injuries.
- Do not exceed the maximum recommended number of people. Regardless of the number of people on board, the total weight of people and equipment must never exceed the maximum recommended load. Always use the seats/seating spaces provided.
- When loading the craft, never exceed the maximum recommended load. Carefully distribute the weight appropriately to ensure the craft remains level. Avoid placing heavy items in the front.
- The maximum recommended load includes the weight of all people on board, all provisions and personal effects, any equipment not attached to the craft, cargo (if any) and all consumable liquids (water, fuel, etc.).
- When using the boat, life-saving devices such as life jackets and buoys should be inspected beforehand and used at all times.
- Buckets, water scoops and air pumps should always be available in case of air leakage or if the boat takes on water.
- When the boat is in motion, all passengers must remain seated at all times to avoid falling overboard.
- Use the boat in protected shore-zones, up to 300 m (984 ft.). Be aware of natural factors such as wind, tidewaters and tidal waves.
- Be careful when landing on the shore. Sharp and rough objects such as rocks, cement, shells, glass, etc. may puncture the boat.
- If one chamber is punctured when the boat is in the water, it may be necessary to fully inflate the other air chamber to prevent the boat from sinking.
- To avoid damage, do not drag the boat on rough surfaces.
- It is the responsibility of the owner/operator to have at least a bucket/bailer on board, secured against accidental loss.
- Be responsible, and do not neglect the safety rules as this could jeopardize your life and the lives of others.
- Know how to operate a boat. Check in your local area for information and/or training as needed. Inform yourself about local regulations and dangers related to boating and/or other water activities.
- Drawings are for illustration purposes only. May not reflect actual product. Not to scale.

SAVE THESE INSTRUCTIONS

TECHNICAL SPECIFICATIONS

Item	Size	Recommended working pressure	Floor board pressure	Maximum load capacity	Maximum motor power
65046	2.30m x 1.30m x 33cm 7'6" x 5'1" x 13"	3.5 psi 0.24 bar	5 psi 0.35 bar	258 kg (568.8 lbs.) 2 adults	2.25 kW (3 hp)

- The floorboards must be assembled before inflating the hull.
- Extended exposure to sun can shorten the lifespan of your boat. We suggest to not leave boats in direct sunlight for more than 1 hour after use.
- Pressure gauge is for inflation purpose only, and the value of the pressure gauge is just for reference, should not be used as a precision instrument.
- Only use Bestway® approved inflation pumps.
- Never use motor-driven high-pressure air pumps as this may result in over-inflation.
- Under and over-inflation will result in safety hazards.
- Always check the inflation pressure before using the boat.
- Never stand on or rest objects on the boat during inflation.
- Never open the cap of air valve while the boat is in use.
- Be sure the valve is tightly closed before using the boat.
- When the oars are not in use, lock the oars into the oar clasps to avoid damage.

OUTBOARD MOTOR INSTALLATION

- With the boat fully inflated and in the water, attach your outboard motor onto Engine Mount at the center of the Transom.
- Ensure the motor is always fixed on the Transom.
- Read the instructions of the outboard motor for correct installation and operation.
- Overpowering a boat can result in serious injury, death or boat damage. The maximum motor power to be used see marking on the product.

MAINTENANCE

- Inflate according to the PSI marked besides the valve.
- To avoid the long-time exposure to sunshine or rain, put the outside cover on top for protection when it not being used.
- Clean it with mild soap water and soft cloth in case it is not going to be used for a long time. Dry it before putting them away. Store it at a dry and shady place and keep it out of reach of Children.
- Use the spanner to tighten the air valve if it is leaking .

STORAGE

- Remove the oars from the oarlocks. Keep all accessories for future use.
- Carefully clean the boat using a mild soap with clean water. Do not use acetone, acid, and/or alkaline solutions.
- Use a cloth to gently dry all surfaces. Do not dry the product in direct sunlight. Also, never dry with equipment such as electric blowers. Doing so will cause damage and shorten the boat's life span.
- To deflate, open the Air Valves pushing the control stem in and rotating until the valves stay open. Deflate all the hull chambers at the same time so the air-pressure drops together. This will prevent damage form occurring to the boat's inner structures.
- Fold the boat from front to back to remove additional air.

REPAIR

The glue is not included in the repair kit due to shipping constraints. You can find silicone-based glue at most retail outlets. Carefully read the warning labels and closely follow instructions on the back of glue before attempting the following repair steps:

- Fully clean the area to be repaired.
- Cut the correct size from the repair patch material.
- Apply only the amount of glue needed to cover the repair site.
- Press the repair patch firmly to repair site for 30 seconds.
- Wait for 1 hour before inflation.

PLEASE KEEP THIS MANUAL IN A SECURE PLACE, AND HAND IT OVER TO THE NEW OWNER WHEN YOU SELL THE CRAFT.